



US 20150372072A1

(19) **United States**

(12) **Patent Application Publication**
XIONG et al.

(10) **Pub. No.: US 2015/0372072 A1**
(43) **Pub. Date: Dec. 24, 2015**

(54) **ORGANIC LIGHT EMITTING DIODE
DISPLAY PANEL, ORGANIC LIGHT
EMITTING DIODE DISPLAY DEVICE, AND
METHOD FOR FABRICATING ORGANIC
LIGHT EMITTING DIODE DISPLAY PANEL**

H01L 29/786 (2006.01)
H01L 51/56 (2006.01)

(52) **U.S. Cl.**
CPC *H01L 27/3279* (2013.01); *H01L 27/3262*
(2013.01); *H01L 27/3248* (2013.01); *H01L*
51/56 (2013.01); *H01L 29/66742* (2013.01);
H01L 29/786 (2013.01)

(71) Applicants: **Shanghai Tianma AM-OLED Co.,
Ltd., Shanghai (CN); Tianma
Micro-Electronics Co., Ltd., Shenzhen
(CN)**

(57) **ABSTRACT**

(72) Inventors: **Zhiyong XIONG, Shanghai (CN);
Zhanghe Zeng, Shanghai (CN); Dong
Qian, Shanghai (CN)**

An organic light emitting diode (OLED) display panel is disclosed. The display panel includes a substrate, and a Thin-film Transistor (TFT) disposed on the substrate. The TFT includes a source electrode, and a drain electrode. The display panel also includes a power line disposed above the substrate, an auxiliary electrode electrically connected to the power line, and a signal input terminal, electrically connected to the power line and providing an input signal. A first collective portion of the auxiliary electrode and the power line has a first length and a first resistance. A second collective portion of the auxiliary electrode and the power line has a second length and a second resistance. The first collective portion is between the second collective portion and the signal input terminal. The first length is equal to the second length, and the first resistance is greater than the second resistance.

(21) Appl. No.: **14/591,913**

(22) Filed: **Jan. 7, 2015**

(30) **Foreign Application Priority Data**

Jun. 23, 2014 (CN) 201410284218.4

Publication Classification

(51) **Int. Cl.**
H01L 27/32 (2006.01)
H01L 29/66 (2006.01)

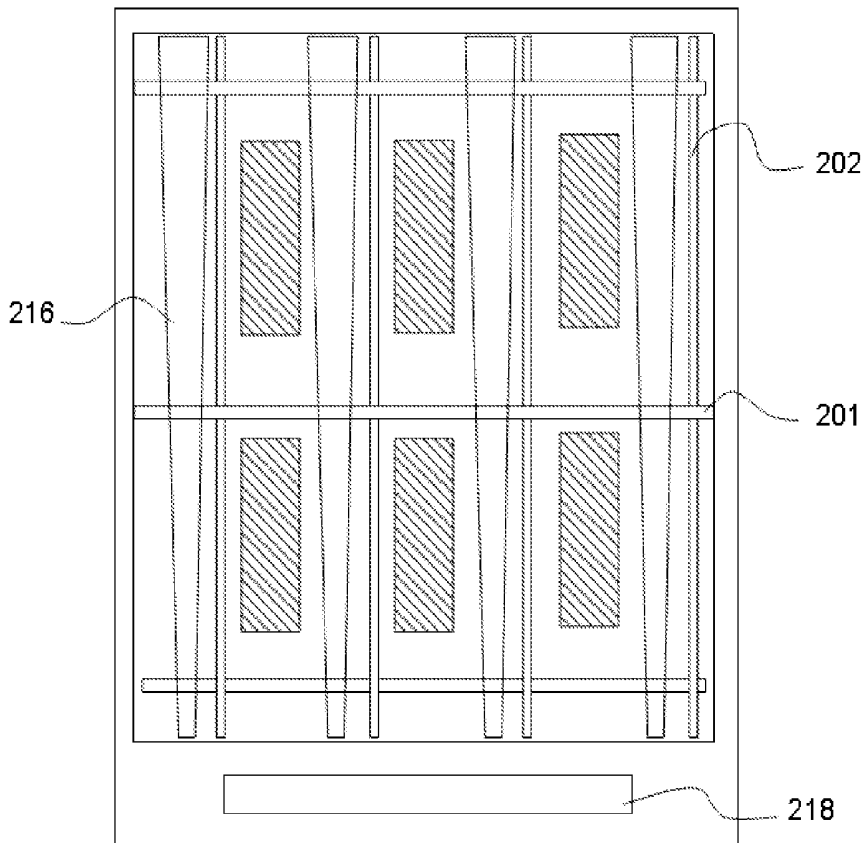

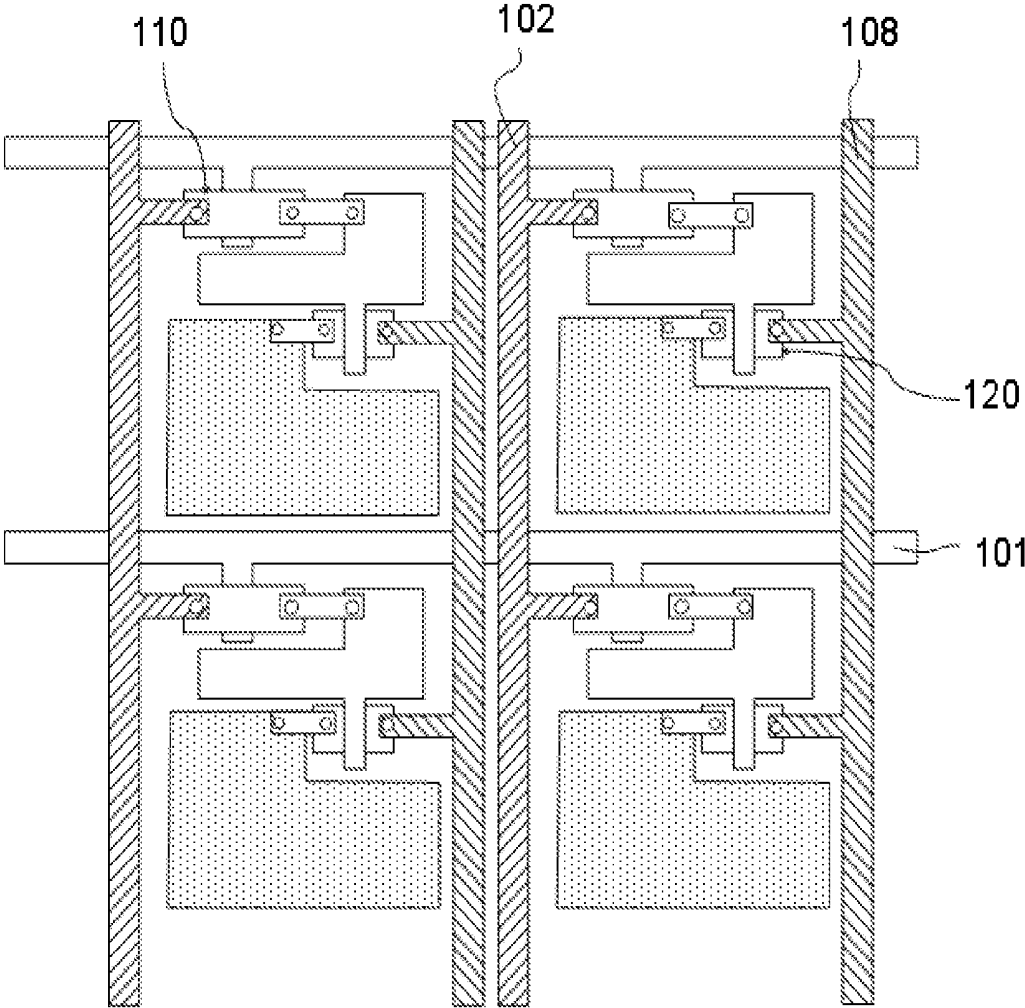

FIG. 1

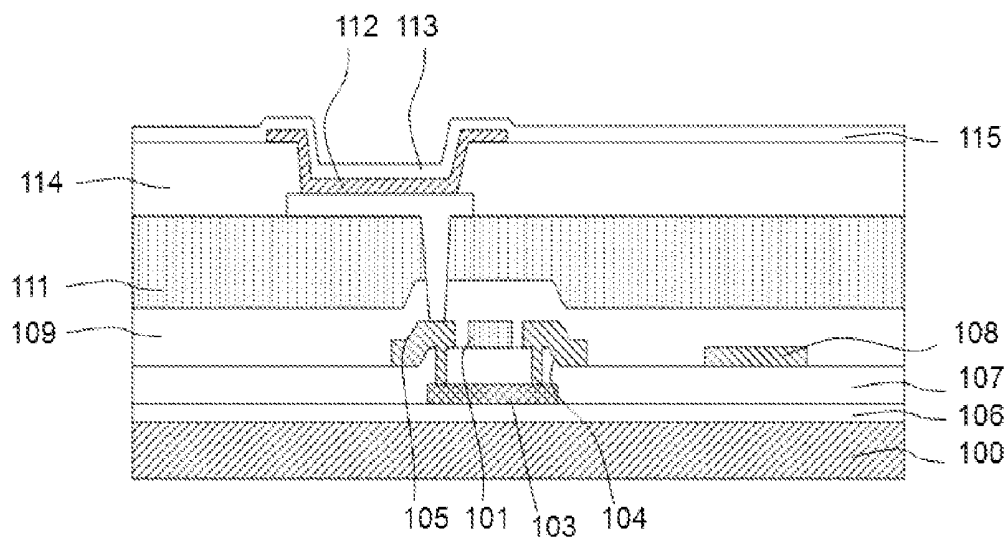

FIG. 2

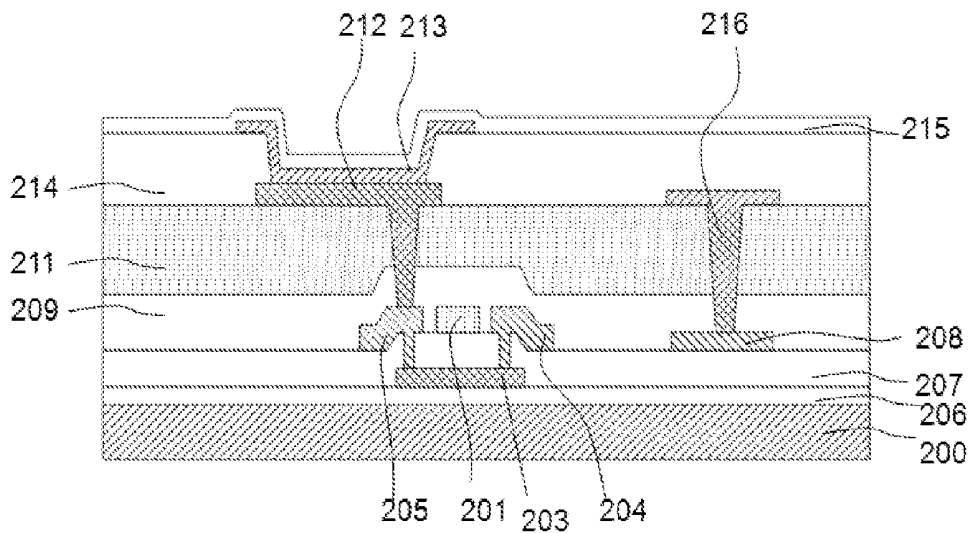

FIG. 3

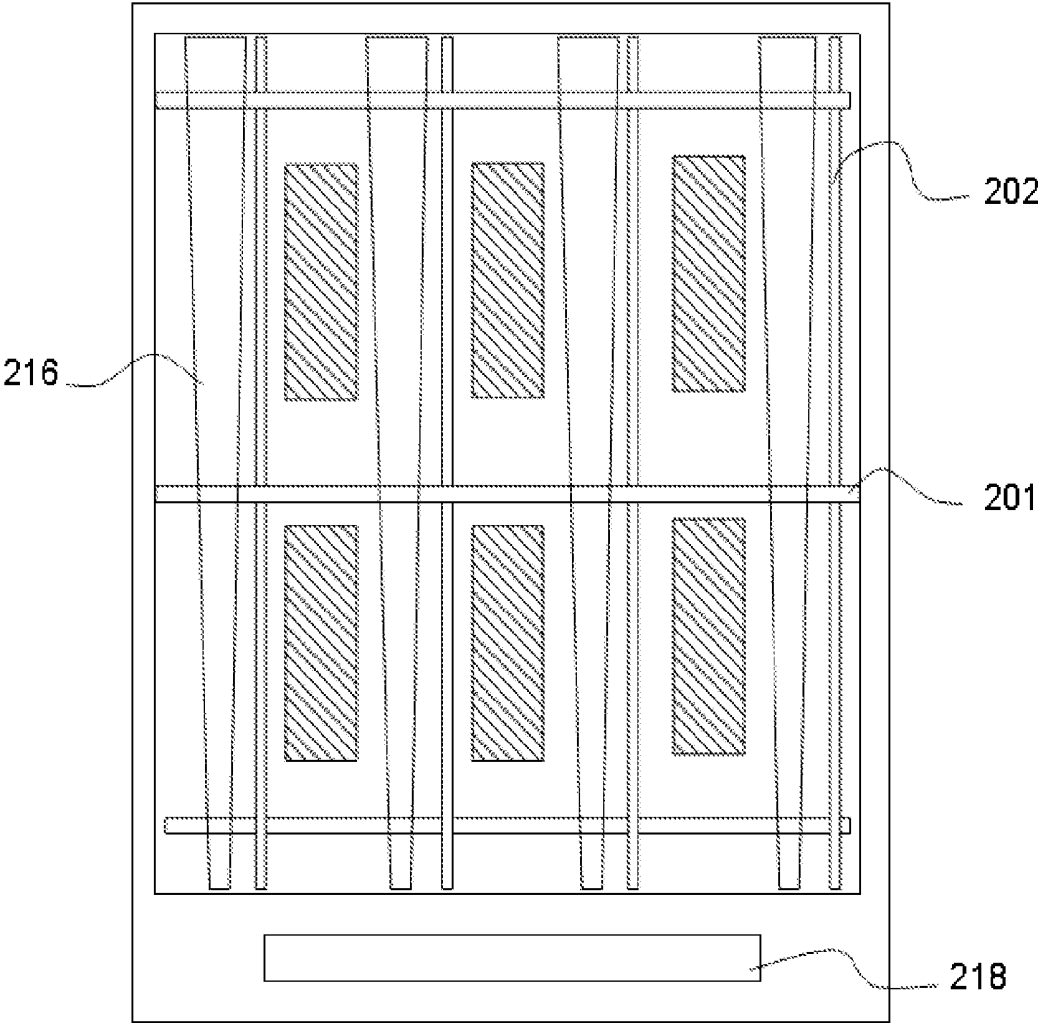

FIG. 4

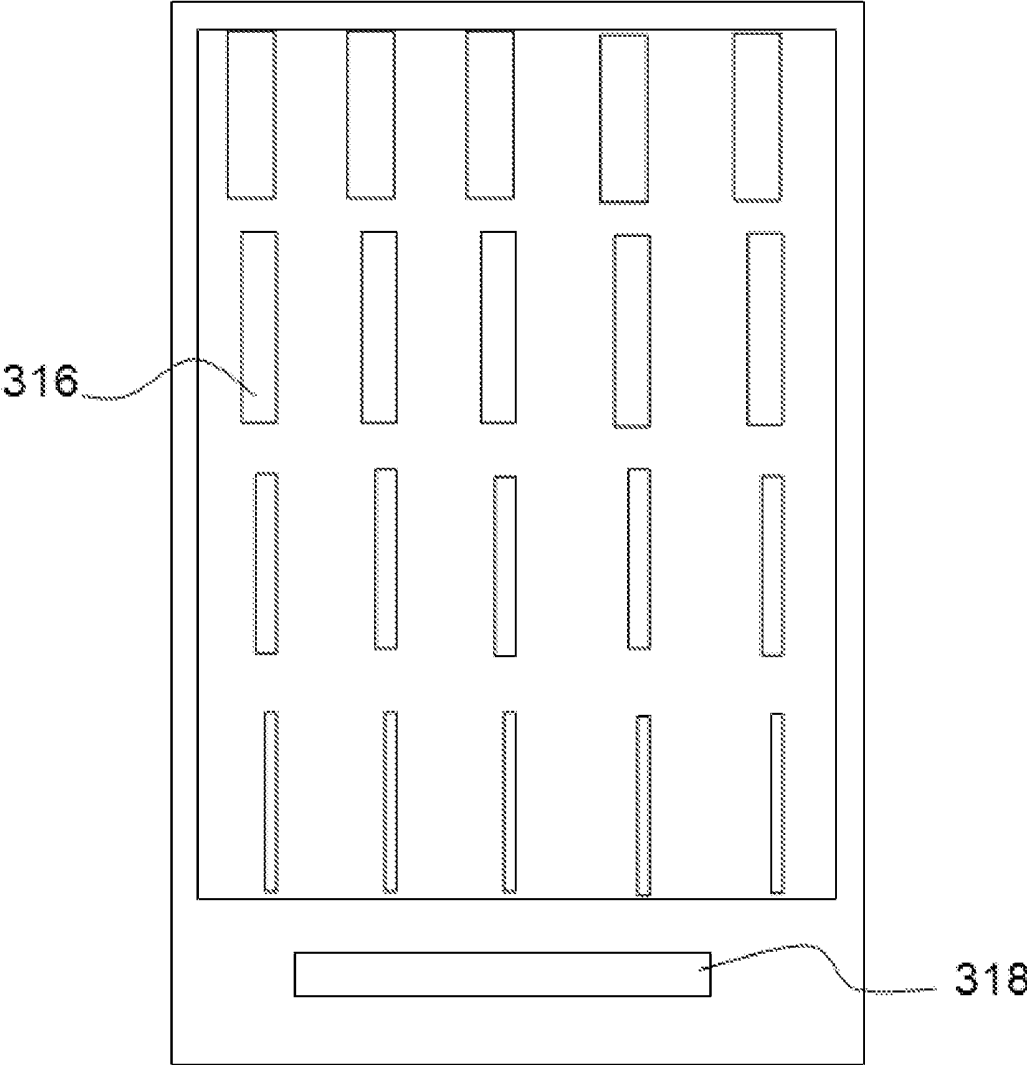

FIG. 5

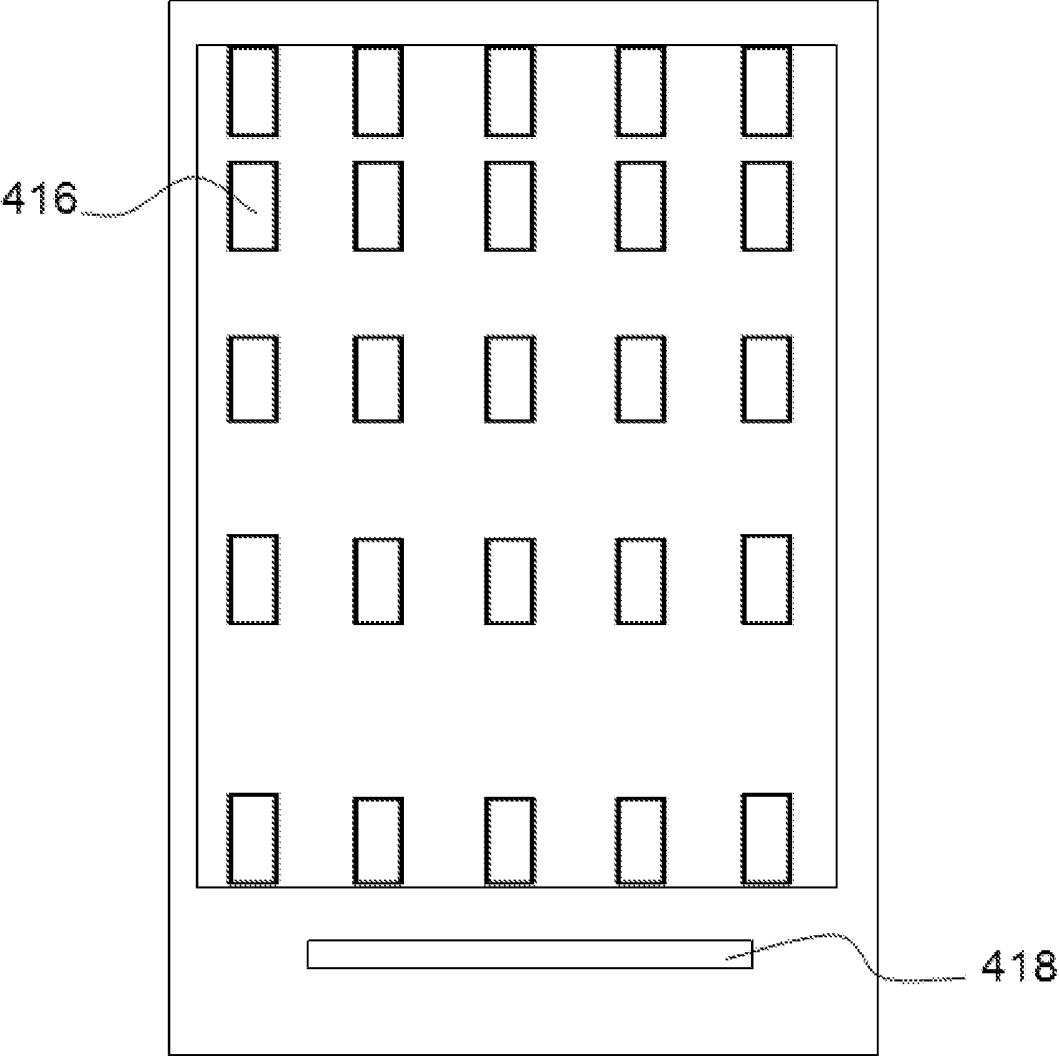

FIG. 6

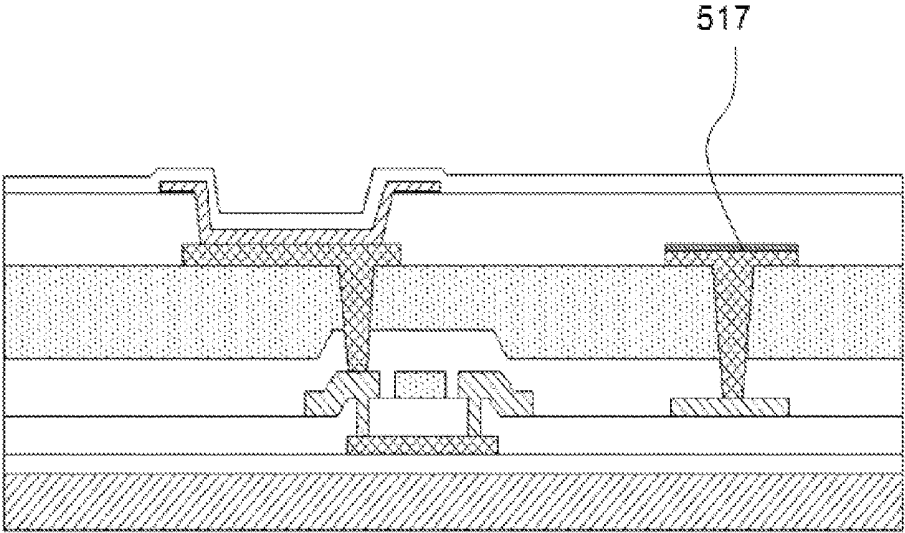

FIG. 7

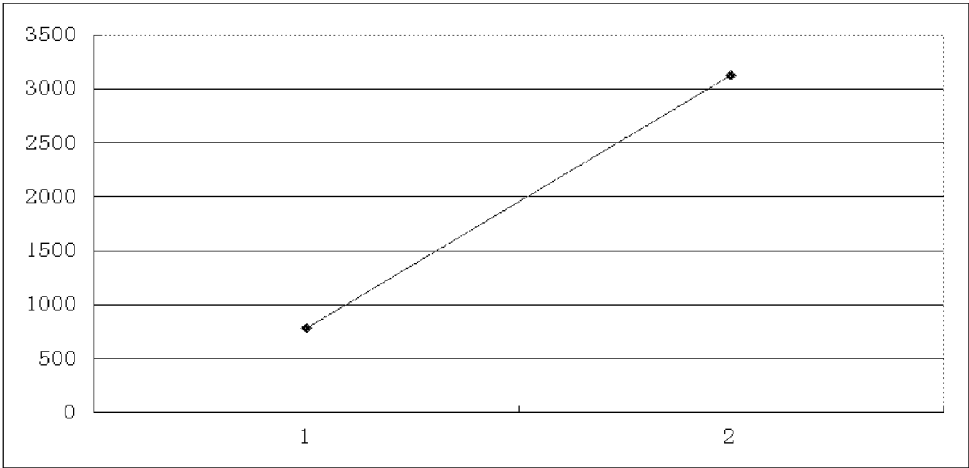

FIG. 8a

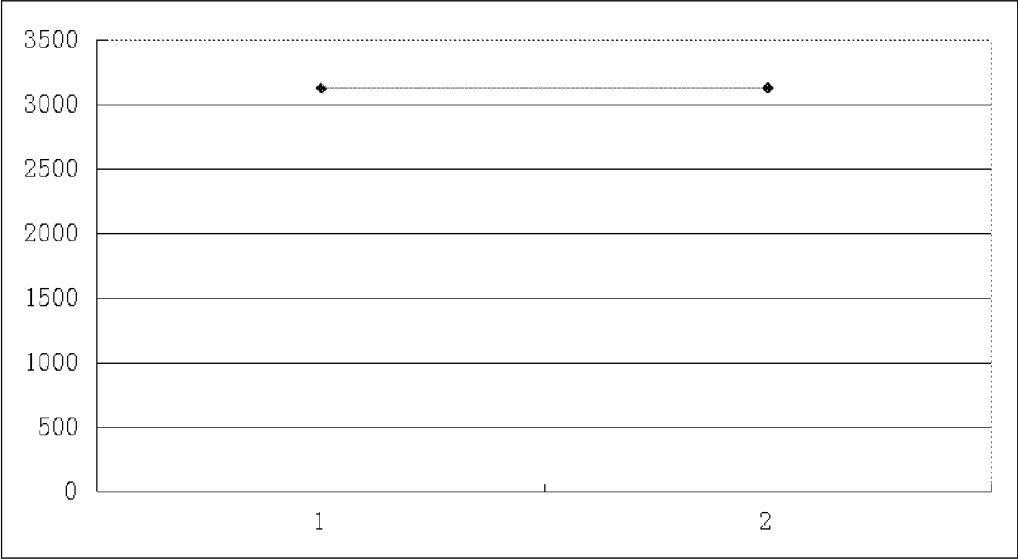

FIG. 8b

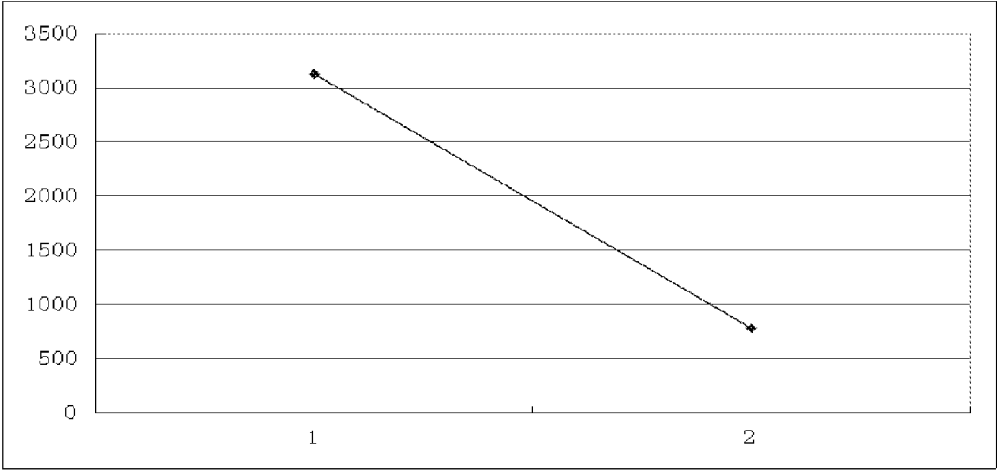

FIG. 8c

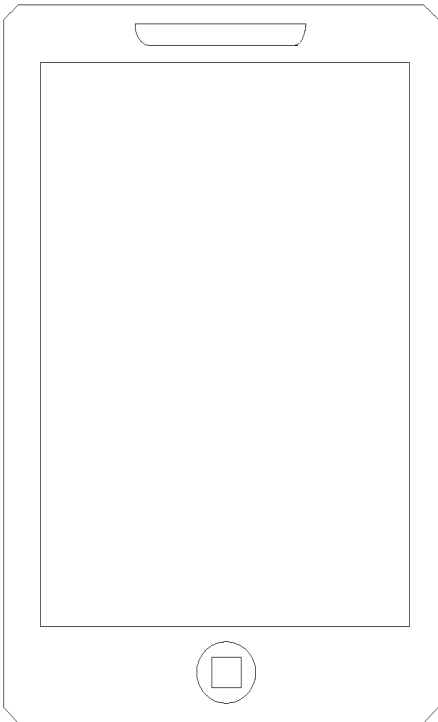

FIG. 9

**ORGANIC LIGHT EMITTING DIODE
DISPLAY PANEL, ORGANIC LIGHT
EMITTING DIODE DISPLAY DEVICE, AND
METHOD FOR FABRICATING ORGANIC
LIGHT EMITTING DIODE DISPLAY PANEL**

CROSS-REFERENCES TO RELATED
APPLICATIONS

[0001] This application claims the benefit of priority to Chinese Patent Application No. 201410284218.4, filed with the Chinese Patent Office on Jun. 23, 2014 and entitled “ORGANIC LIGHT EMITTING DIODE DISPLAY PANEL, ORGANIC LIGHT EMITTING DIODE DISPLAY DEVICE, AND METHOD FOR FABRICATING ORGANIC LIGHT EMITTING DIODE DISPLAY PANEL”, the content of which is incorporated herein by reference in its entirety.

FIELD OF THE INVENTION

[0002] The present application relates to the field of display, particularly to an organic light emitting diode display panel, an organic light emitting diode display device and a method for fabricating the organic light emitting diode display panel thereof.

BACKGROUND OF THE INVENTION

[0003] In an organic light emitting diode (OLED) device, electroluminescence of organic fluorescent compounds is used instead of backlight, thereby endowing the OLED device with a small size and good portability. In addition, the OLED device further has advantages such as a wide viewing angle and a fast response.

[0004] The OLED device has a cathode, an anode, and an organic film made of an organic compound provided between the cathode and the anode. When a voltage is applied between the cathode and the anode, holes migrate, via a Hole Transport Layer (HTL), from an electrode with a positive electrical potential to an organic light emitting layer; and electrons migrate, via an Electron Transport Layer (ETL), from an electrode with a negative electrical potential to the organic light emitting layer. Excitons are generated through recombination of the holes and the electrons, and are excited to emit light, providing light for the OLED device.

BRIEF SUMMARY OF THE INVENTION

[0005] One inventive aspect is an organic light emitting diode (OLED) display panel. The display panel includes a substrate, and a Thin-film Transistor (TFT) disposed on the substrate. The TFT includes a source electrode, and a drain electrode. The display panel also includes a power line disposed above the substrate, an auxiliary electrode electrically connected to the power line, and a signal input terminal, electrically connected to the power line and providing an input signal. A first collective portion of the auxiliary electrode and the power line has a first length and a first resistance. A second collective portion of the auxiliary electrode and the power line has a second length and a second resistance. The first collective portion is between the second collective portion and the signal input terminal. The first length is equal to the second length, and the first resistance is greater than the second resistance.

[0006] Another inventive aspect is an OLED display device, including an OLED display panel. The OLED display

panel includes a substrate, and a Thin-film Transistor (TFT) disposed on the substrate. The TFT includes a source electrode, and a drain electrode. The display panel also includes a power line disposed above the substrate, an auxiliary electrode electrically connected to the power line, and a signal input terminal, electrically connected to the power line and providing an input signal. A first collective portion of the auxiliary electrode and the power line has a first length and a first resistance. A second collective portion of the auxiliary electrode and the power line has a second length and a second resistance. The first collective portion is between the second collective portion and the signal input terminal. The first length is equal to the second length, and the first resistance is greater than the second resistance.

[0007] Another inventive aspect is a method for fabricating an OLED display panel. The method includes providing a substrate, forming, above the substrate, a TFT including a source electrode and a drain electrode, and forming a power line above the substrate. The method also includes forming a first electrode above the TFT, the first electrode being electrically connected to the source electrode or the drain electrode. The method also includes forming an auxiliary electrode, where a resistance per unit length of the auxiliary electrode changes along the auxiliary electrode, and where the auxiliary electrode is electrically connected to the power line. The method also includes forming an organic layer above the first electrode, and forming a second electrode above the organic layer.

BRIEF DESCRIPTION OF THE DRAWINGS

[0008] FIG. 1 is a plan view of a conventional OLED device;

[0009] FIG. 2 is a sectional view of a pixel of the conventional OLED device;

[0010] FIG. 3 is a sectional view of a pixel of an OLED display panel according to an embodiment of the application;

[0011] FIG. 4 is a plan view of an OLED display panel according to an embodiment of the application;

[0012] FIG. 5 is a plan view of an OLED display panel according to an embodiment of the application;

[0013] FIG. 6 is a plan view of an OLED display panel according to an embodiment of the application;

[0014] FIG. 7 is a sectional view of a pixel of an OLED display panel according to an embodiment of the application;

[0015] FIG. 8a-FIG. 8c show simulated values of resistances according to an embodiment of the application;

[0016] FIG. 9 is a schematic diagram of an OLED display device according to an embodiment of the application.

DETAILED DESCRIPTION OF THE PREFERRED
EMBODIMENTS

[0017] To better explain technical solutions according to embodiments of the application, clear and complete descriptions are given hereinafter in conjunction with drawings in the embodiments. Apparently, described embodiments are merely a few embodiments of the application, rather than all embodiments. Any other embodiments obtained by those skilled in the art without creative work are within the scope of the application.

[0018] FIG. 1 is a top view of a conventional OLED device. The OLED device includes multiple pixels. Pixel units are defined by intersections of gate lines 101 and data lines 102, and the gates lines 101 are insulated from the data lines 102.

Power lines **108** are disposed in parallel with the data lines **102**. Each pixel unit includes at least two thin film transistors (TFTs). As shown in FIG. 1, numerical symbol **110** represents a switch TFT and numerical symbol **120** represents a driving TFT. The switch TFT **110** receives a signal transmitted via the gate line **101**, to control a switch to forward a signal transmitted via the data line **102** to the driving TFT **120**. The driving TFT further controls an intensity of a current input to an OLED element via the power line **108**. In general, the OLED device may further include one or more storage capacitors (not shown in FIG. 1) to store data signals transmitted by the switch TFT **110**.

[0019] FIG. 2 is a sectional view of a pixel of the conventional OLED device. A buffer layer **106** is disposed on a substrate **100**. An active layer **103** is disposed on the buffer layer **106**. A gate insulation layer **107** is provided over the active layer **103**. A gate electrode **101** is arranged on the gate insulation layer **107**, and a source electrode **104** and a drain electrode **105** are insulatively arranged at two sides of the gate electrode **101** and are located on the gate insulation layer **107**. The source electrode **104** and the drain electrode **105** are electrically connected to the active layer **103** via holes penetrating through the gate insulation layer **107**. The power line **108** is provided on the gate insulation layer **107**. A passivation film **109** and a planar film **111** are disposed above the TFT. A first electrode **112** is disposed on the planar film **111**, and the first electrode **112** is electrically connected to the drain electrode **105**. A pixel defining layer **114** is disposed over the first electrode **112**. The pixel defining layer **114** has a sunken area, and an organic layer **113** is disposed at the sunken area. In general, the organic layer **113** may include an HTL, a hole injection layer, a light emitting layer, an ETL, and an electron injection layer. The organic layer **113** may be disposed at the sunken area of the pixel defining layer **114**, or disposed on an entire surface of the pixel defining layer **114**.

[0020] FIG. 3 is a sectional view of a pixel of an OLED display panel according to an embodiment of the application. Similarly, the OLED display panel according to the embodiment of the application includes a substrate **200**, a buffer layer **206**, an active layer **203**, a gate electrode **201**, a source electrode **204**, a drain electrode **205**, a gate insulation layer **207**, a power line **208** arranged at a same layer as the drain electrode **205** and the source electrode **204**, a passivation film **209**, a planar film **211**, a first electrode **212**, an organic layer **213** and a pixel defining layer **214**. The arrangement of the above components and electrical connections between the above components are same as those in the conventional OLED device, and may be referred to the description of the conventional OLED device. In a conventional design, voltage drop is generated along the power line due to the resistance of the power line, and the voltage drop aggravates at a place far away from a signal input terminal. The voltage drop results in a nonuniform brightness and a poor display effect. The OLED device provided in the application further includes an auxiliary electrode **216**, and the auxiliary electrode **216** is electrically connected to the power line **208**. A total resistance of the auxiliary electrode **216** and the power line **208** electrically connected to each other is decreased, thereby alleviating the voltage drop. Under a basis that the auxiliary electrode is electrically connected with the power line and the total resistance is decreased, the auxiliary electrode may be fabricated in any of the layers, or may be fabricated into a separate layer, or the auxiliary electrode and other components may be fabricated in a same layer. Optionally, the auxiliary electrode **216**

and the first electrode **212** may be fabricated in a same layer. Optionally, the auxiliary electrode **216** and the first electrode **212** may be made of a same material and fabricated with a same process of etching; hence, no additional process is required to form the auxiliary electrode. Optionally, the auxiliary electrode may be located above the power line, and in this case, an aperture ratio of the device may not be affected because the auxiliary electrode is located in a non-display region.

[0021] Since the voltage drop aggravates as a distance from the signal input terminal increases, the auxiliary electrode in the application may be designed into an uneven shape to better compensate the power line. Optionally, for two portions of a combination of the auxiliary electrode and the power line, each portion having a first length, the resistance of a portion far from the signal input terminal is less than the resistance of a portion close to the signal input terminal. With the uneven design, a portion of the power line, having a heavy voltage drop, is connected in parallel with a resistor having a small resistance, to effectively alleviate the voltage drop at the portion of the power line, and the voltage drop along the power line is small due to the resistance compensation. The above effects may be achieved by adjusting the size, the shape or the resistivity of the auxiliary electrode, or may be achieved by adjusting the size, the shape, or the resistivity of the power line. Optionally, the resistance per unit length of the auxiliary electrode decreases as a distance from the per unit length of the auxiliary electrode to the signal input terminal increases.

[0022] FIG. 4 is a top view of an OLED display panel according to an embodiment of the application. Pixel units are defined by intersections of gate lines **201** and data lines **202**, and the gate lines **201** are insulated from the data lines **202**. Auxiliary electrodes **216** are parallel with the data lines **202**, and are electrically connected to power lines (not shown in FIG. 4) to collaboratively transmit an electrical signal emitted from a signal input terminal **218**. The signal input terminal **218** may be an integrated circuit, transmitting the electrical signal to the power lines to control a brightness of the OLED display panel. In general, the signal input terminal **218**, i.e., the integrated circuit is electrically connected to a fabricated display panel, to control displaying of the panel by inputting the signal. According to an embodiment, the resistance per unit length of the combination of the auxiliary electrode and the power line gradually decreases as a distance from the per unit length of the combination to the signal input terminal increases. The width of per unit length of the auxiliary electrode **216** gradually increases as a distance from the per unit length of auxiliary electrode **216** to the signal input terminal **218** increases. With this design, the resistance of the per unit length of the auxiliary electrode **216** gradually decreases as the distance from the per unit length of the auxiliary electrode **216** to the signal input terminal increases, and consequently, a portion of the power line far from the signal input terminal is provided with a large compensation, thus effectively compensating the voltage drop at a place far from the signal input terminal, and alleviating the problem of nonuniform display. According to an embodiment, the first length mentioned above may be any length larger than zero and less than a total length of the auxiliary electrode. In fact, alternatively, a compensation for alleviating the voltage drop may be achieved by an uneven design of the power line. According to the application, optionally, the width of the auxiliary electrode is larger than the width of the power line, and the voltage drop

along the power line may be reduced more effectively by this design. In general, the wider the auxiliary electrode, the smaller the resistance of the auxiliary electrode, and the better the compensation for the voltage drop along the power line. Therefore, in the application, under a premise that no short circuit may occur between the auxiliary electrode and other electrodes and the display effect may not be affected, the auxiliary electrode may be made as wide as possible.

[0023] Compared with adjusting the shape of the power line, the technical solution of the application has advantages as follows. Only the first electrode is located in a same layer as the auxiliary electrode, while many components are located in a same layer as the power line. Therefore, if any adjustment is made to the shape of the power line, the components and the power line, located in a same layer, may influence each other, thereby affecting the display effect. However, in the application, with an adjustment made to the shape of the auxiliary electrode, a compensation for resistance is achieved without affecting the display effect, and the process is also easier to operate.

[0024] According to other embodiments of the application, the uneven design of the auxiliary electrode may further have other implementations. FIG. 5 is a top view of an OLED display panel according to an embodiment of the application. As shown in FIG. 5, each auxiliary electrode 316 includes multiple discrete sub-auxiliary electrodes. The farther one sub-auxiliary electrode is away from a signal input terminal 318, the larger the width of the sub-auxiliary electrode is. According to an embodiment, the first length mentioned above is a length larger than the sum of the length of the sub-auxiliary electrode and a distance between sub-auxiliary electrodes. In the discontinuous design and along a direction departing from the signal input terminal, for any two portions of a combination of the auxiliary electrode and the power line, each portion having the first length, a resistance of one portion differs from a resistance of the other portion. Optionally, the length of each sub-auxiliary electrode is larger than a distance between two adjacent scan lines; accordingly, an electrical signal may be transmitted more effectively. With the discontinuous arrangement, total resistances at places with different distances from the signal input terminal can be consistent and the voltage drop is alleviated. Furthermore, in some designs of panels, patterns may be arranged at places of the auxiliary electrodes. Here with the discontinuous arrangement, the routing on the panel may not be affected.

[0025] FIG. 6 is a top view of an OLED display panel according to an embodiment of the application. Each auxiliary electrode 416 includes multiple discrete sub-auxiliary electrodes. As a distance from a signal input terminal 418 increases, distances between the respective sub-auxiliary electrodes gradually decrease, and widths of the sub-auxiliary electrodes may be same with each other or may gradually increase. With the discontinuous arrangement, resistances at places with different distances from the signal input terminal are consistent and the voltage drop is alleviated. Furthermore, in some designs of panels, routing may be arranged at places of the auxiliary electrodes. Here with the discontinuous arrangement, the routing on the panel may not be affected. It should be noted that, for clarifying structures of the display panel, data lines and gate lines are not shown in FIG. 5 and FIG. 6, and detailed structures may be referred to FIG. 4.

[0026] According to an embodiment of the application, the auxiliary electrode may be made of materials with different resistivities. In particular, the auxiliary electrode may be

made of multiple types of materials. A portion of the auxiliary electrode far from the signal input terminal is made of a material having a small resistivity, and a portion of the auxiliary electrode close to the signal input terminal is made of a material having a large resistivity; hence, an effective compensation for the power line is achieved. Alternatively, the auxiliary electrode may be made of a single type of material. Optionally, as a distance from the signal input terminal increases, different concentrations of impurity are doped into the single type of material to implement a gradually changed resistance along the auxiliary electrode. For example, the conductivity of Indium Tin Oxide (ITO) may be changed by doping, into the ITO, one or more kinds of metallic elements such as Ta, Nd and Sn, and an uneven change of the resistivity of a host material ITO may be achieved by doping different concentrations of metallic elements at different portions of the auxiliary electrode. It should be noted that, the resistivity of the material may gradually decrease as the distance from the signal input terminal increases. Alternatively, the auxiliary electrode may include multiple segments, the resistivity maintains the same within each segment, while the resistivities of respective segments decrease as distances from the respective segments to the signal input terminal increase.

[0027] In addition, other shapes or methods may be applied to ensure that a portion far away from the signal input terminal has a small resistance, for example, a thickness may be adjusted, or a second auxiliary electrode may be further connected in parallel with the power line. The methods given above may be used in combination, and possible combinations are all within the idea of the application and are not enumerated herein.

[0028] According to an embodiment of the application, a shielding layer 517 (as shown in FIG. 7) may be disposed on an auxiliary electrode 516. The shielding layer 517 may be made of an organic material, having a weak reflection effect or no reflection effect of light. In the case that the auxiliary electrode 516 is made of a reflective material (such as metal), an external light may be reflected by the auxiliary electrode 516, thereby decreasing a contrast of the display panel. The shielding layer may prevent the reflection of an external background light. To prevent the reflection, optionally, the auxiliary electrode 516 may be made of a material with a weak reflection effect or no reflection effect of light. With this design, the auxiliary electrode 516 may compensate the voltage drop along the power line without affecting the contrast of the display panel.

[0029] FIG. 8a-FIG. 8c illustrate simulated values of resistances of three different shapes of auxiliary electrodes in a 5.5-inch Active Matrix Organic Light Emitting Diode (AMOLED) panel. A sheet resistance is 0.56 sq. An ordinate represents the resistance of a wire. In an abscissa, numerical symbol 1 represents an end of an auxiliary electrode close to an IC terminal, numerical symbol 2 represents an end of the auxiliary electrode far away from the IC terminal, and a direction from numerical symbol 1 to numerical symbol 2 represents a direction departing from the IC terminal. In FIG. 8a, a width of the auxiliary electrode gradually decreases along the direction departing from the IC terminal, and a corresponding resistance increases from 750 Ω to 3250 Ω . A compensation is weak at a place far from the IC terminal. Since a voltage drop is large at a place far from the IC terminal, this shape design of the auxiliary electrode has no significant effect in compensating the voltage drop. In FIG. 8b, a width of the auxiliary electrode keeps constant along the

direction departing from the IC terminal, and a corresponding resistance is maintained at about 3200 Ω . The auxiliary electrode provides a same resistance compensation to a whole power line. In fact, the voltage drop gradually aggravates along the direction departing from the IC terminal. In compensating the aggravating voltage drop with the same resistance compensation, the voltage drop at a place far from the IC terminal may not be effectively compensated. In FIG. 8c, a width of the auxiliary electrode gradually increases along the direction departing from the IC terminal, and a corresponding resistance decreases from 3250 Ω to 750 Ω . Therefore, at a place far from the IC terminal where the voltage drop is large, an effect of compensation is significant. With this design, the large voltage drop at the place far from the IC terminal is effectively compensated.

[0030] Referring to FIG. 9, an OLED display device including the foregoing OLED display panel is further disclosed in the application.

[0031] A method for fabricating an OLED display panel is further disclosed in the application. The method includes: providing a substrate; forming, on the substrate, an TFT including a source electrode and a drain electrode; forming a power line; forming a first electrode above the TFT, the first electrode being electrically connected to the source electrode or to the drain electrode; forming an auxiliary electrode, where resistance per unit length of the auxiliary electrode changes along the auxiliary electrode and the auxiliary electrode is electrically connected to the power line; forming an organic layer over the first electrode; and forming a second electrode above the organic layer. Optionally, the auxiliary electrode is formed in a same layer as the first electrode. Optionally, the auxiliary electrode and the first electrode are formed in a same step.

[0032] The idea of reducing the resistance of an electrode along the direction departing from the signal input terminal as described in the application is also applicable to other aspects such as designing shapes of a cathode, an anode, or an auxiliary electrode thereof in an OLED device.

[0033] In the application, the auxiliary electrode may be made into a single layer or multiple layers. The auxiliary electrode may be made of metal or ITO. Or an ITO layer may be provided over a metallic layer, such as, an Ag-ITO structure, an Al-ITO structure, or a Mo-ITO structure. The passivation film may be made of SiO₂ or SiN_x. The planar film may be made of an organic material such as acrylates or polyimides. The active layer may be made of polysilicon.

[0034] The terminology "parallel" mentioned in the specification is not limited to completely parallel, and may be appropriately extended to a case of substantially parallel.

[0035] Apparently, various modifications and transformations may be made to the application by those skilled in the art without departing from the spirit and the scope of the application. The application intends to include any modifications and transformations within the scope of claims of the application or within equivalent technologies of the application.

What is claimed is:

1. An organic light emitting diode (OLED) display panel, comprising:

a substrate;

a Thin-film Transistor (TFT) disposed on the substrate, the TFT comprising:

a source electrode, and
a drain electrode;

a power line, disposed above the substrate;

an auxiliary electrode electrically connected to the power line; and

a signal input terminal, electrically connected to the power line and providing an input signal,

wherein a first collective portion of the auxiliary electrode and the power line has a first length and a first resistance, wherein a second collective portion of the auxiliary electrode and the power line has a second length and a second resistance,

wherein the first collective portion is between the second collective portion and the signal input terminal,

wherein the first length is equal to the second length, and wherein the first resistance is greater than the second resistance.

2. The OLED display panel according to claim 1, wherein a collective resistance per unit length of the auxiliary electrode and the power line decreases as distance from the signal input terminal increases.

3. The OLED display panel according to claim 1, wherein the first length is less than a total length of the auxiliary electrode.

4. The OLED display panel according to claim 1, wherein the auxiliary electrode comprises a plurality of discrete sub-auxiliary electrodes.

5. The OLED display panel according to claim 4, wherein the first length is greater than a sum of a length of the sub-auxiliary electrode and a distance between adjacent sub-auxiliary electrodes.

6. The OLED display panel according to claim 4, wherein distances between respective adjacent sub-auxiliary electrodes of the auxiliary electrode decrease along a direction from the signal input terminal.

7. The OLED display panel according to claim 4, wherein the OLED display panel comprises a plurality of pixel units, and a length of the sub-auxiliary electrode is greater than or equal to a length of one pixel unit.

8. The OLED display panel according to claim 1, wherein a width of the auxiliary electrode increases along a direction from the signal input terminal.

9. The OLED display panel according to claim 1, wherein a resistivity of a material, of which the auxiliary electrode is made, decreases along a direction from the signal input terminal.

10. The OLED display panel according to claim 1, wherein a thickness of the auxiliary electrode increases along a direction from the signal input terminal.

11. The OLED display panel according to claim 1, further comprising:

a first electrode, disposed above the TFT and electrically connected to the source electrode or the drain electrode;
an organic layer, disposed above the substrate; and
a second electrode, disposed above the substrate.

12. The OLED display panel according to claim 11, wherein the auxiliary electrode is located in a same layer as the first electrode.

13. The OLED display panel according to claim 1, wherein the auxiliary electrode and the first electrode are made of a same material.

14. The OLED display panel according to claim 1, wherein the auxiliary electrode is disposed above the power line.

15. The OLED display panel according to claim 1, wherein the auxiliary electrode is covered by a layer of an opaque material, or the auxiliary electrode is made of an opaque material.

16. An OLED display device, comprising:
 an OLED display panel, wherein the OLED display panel comprises:
 a substrate;
 a Thin-film Transistor (TFT) disposed on the substrate, the TFT comprising:
 a source electrode, and
 a drain electrode;
 a power line, disposed above the substrate;
 an auxiliary electrode electrically connected to the power line; and
 a signal input terminal, electrically connected to the power line and providing an input signal,
 wherein a first collective portion of the auxiliary electrode and the power line has a first length and a first resistance,
 wherein a second collective portion of the auxiliary electrode and the power line has a second length and a second resistance,
 wherein the first collective portion is between the second collective portion and the signal input terminal,
 wherein the first length is equal to the second length, and
 wherein the first resistance is greater than the second resistance.

17. A method for fabricating an OLED display panel, wherein the method comprises:
 providing a substrate;
 forming, above the substrate, a TFT comprising a source electrode and a drain electrode;

forming a power line above the substrate;
 forming a first electrode above the TFT, the first electrode being electrically connected to the source electrode or the drain electrode;
 forming an auxiliary electrode, wherein a resistance per unit length of the auxiliary electrode changes along the auxiliary electrode and the auxiliary electrode is electrically connected to the power line;
 forming an organic layer above the first electrode; and
 forming a second electrode above the organic layer.

18. The method according to claim **17**, wherein:
 the OLED display panel further comprises a signal input terminal electrically connected to the power line,
 a first collective portion of the auxiliary electrode and the power line has a first length and a first resistance,
 a second collective portion of the auxiliary electrode and the power line has a second length and a second resistance,
 the first collective portion is between the second collective portion and the signal input terminal,
 the first length is equal to the second length, and
 the first resistance is greater than the second resistance.

19. The method according to claim **17**, wherein the auxiliary electrode is formed in a same layer as the first electrode.

20. The method according to claim **17**, wherein the auxiliary electrode and the first electrode are formed in a same step.

* * * * *

专利名称(译)	有机发光二极管显示面板，有机发光二极管显示装置，以及制造有机发光二极管显示面板的方法		
公开(公告)号	US20150372072A1	公开(公告)日	2015-12-24
申请号	US14/591913	申请日	2015-01-07
[标]申请(专利权)人(译)	上海天马AM OLED 天马微电子股份有限公司		
申请(专利权)人(译)	上海天马AM-OLED CO., LTD. 天马微电子股份有限公司.		
当前申请(专利权)人(译)	上海天马AM-OLED CO., LTD. 天马微电子股份有限公司.		
[标]发明人	XIONG ZHIYONG ZENG ZHANGHE QIAN DONG		
发明人	XIONG, ZHIYONG ZENG, ZHANGHE QIAN, DONG		
IPC分类号	H01L27/32 H01L29/66 H01L29/786 H01L51/56		
CPC分类号	H01L27/3279 H01L27/3262 H01L29/786 H01L51/56 H01L29/66742 H01L27/3248 H01L27/124		
优先权	201410284218.4 2014-06-23 CN		
其他公开文献	US9466656		
外部链接	Espacenet USPTO		

摘要(译)

公开了一种有机发光二极管 (OLED) 显示面板。显示面板包括基板和设置在基板上的薄膜晶体管 (TFT)。TFT包括源电极和漏电极。显示面板还包括设置在基板上方的电源线，电连接到电源线的辅助电极和电连接到电源线并提供输入信号的信号输入端子。辅助电极和电源线的第一集合部分具有第一长度和第一电阻。辅助电极和电源线的第二集合部分具有第二长度和第二电阻。第一集合部分在第二集合部分和信号输入端子之间。第一长度等于第二长度，并且第一电阻大于第二电阻。

